

STM80-1.5-ER16

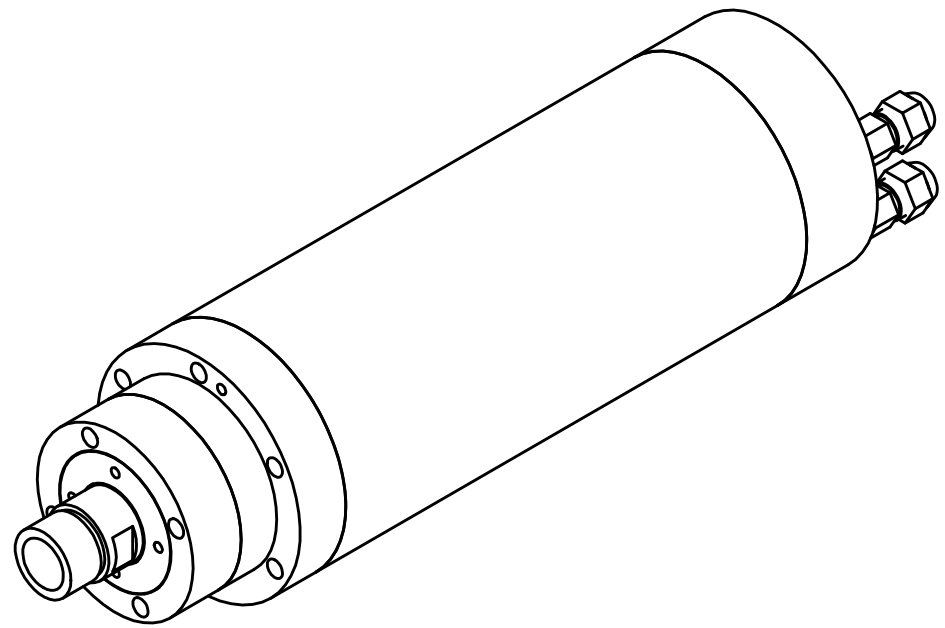
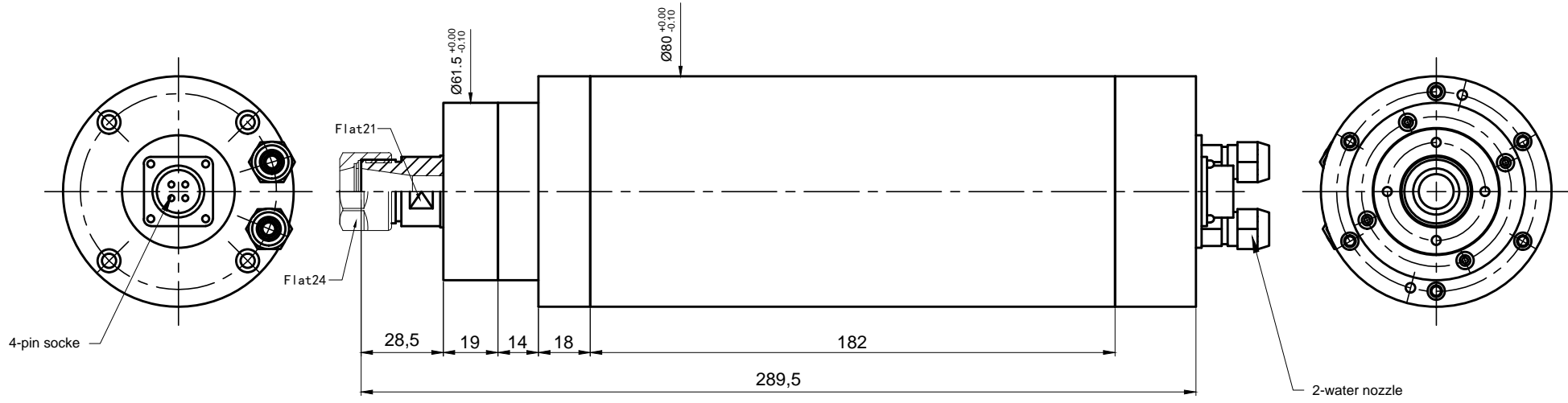

【CAUTION】
Rotating mode: anticlockwise from the shaft extension end

WHD SPINDLE MOTOR							
Power	Voltage	Current	Shaft	Frequency	Speed	Cool	Weight
1.5KW	220V	6A	ER16	400Hz	24000RPM	Water	7.1KG